

**MARINE EVACUATION SYSTEM (MES)
ORIL 100 VENTURI WITH CENTRAL BOWING LINES
ASSOCIATED WITH SMALL INFLATABLE SLIDE (SIS) &
AUTOMATIC EVACUATION SLIDE SYSTEM (ESS)**

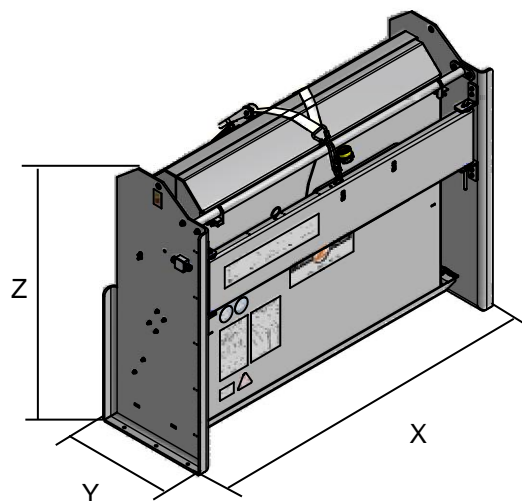
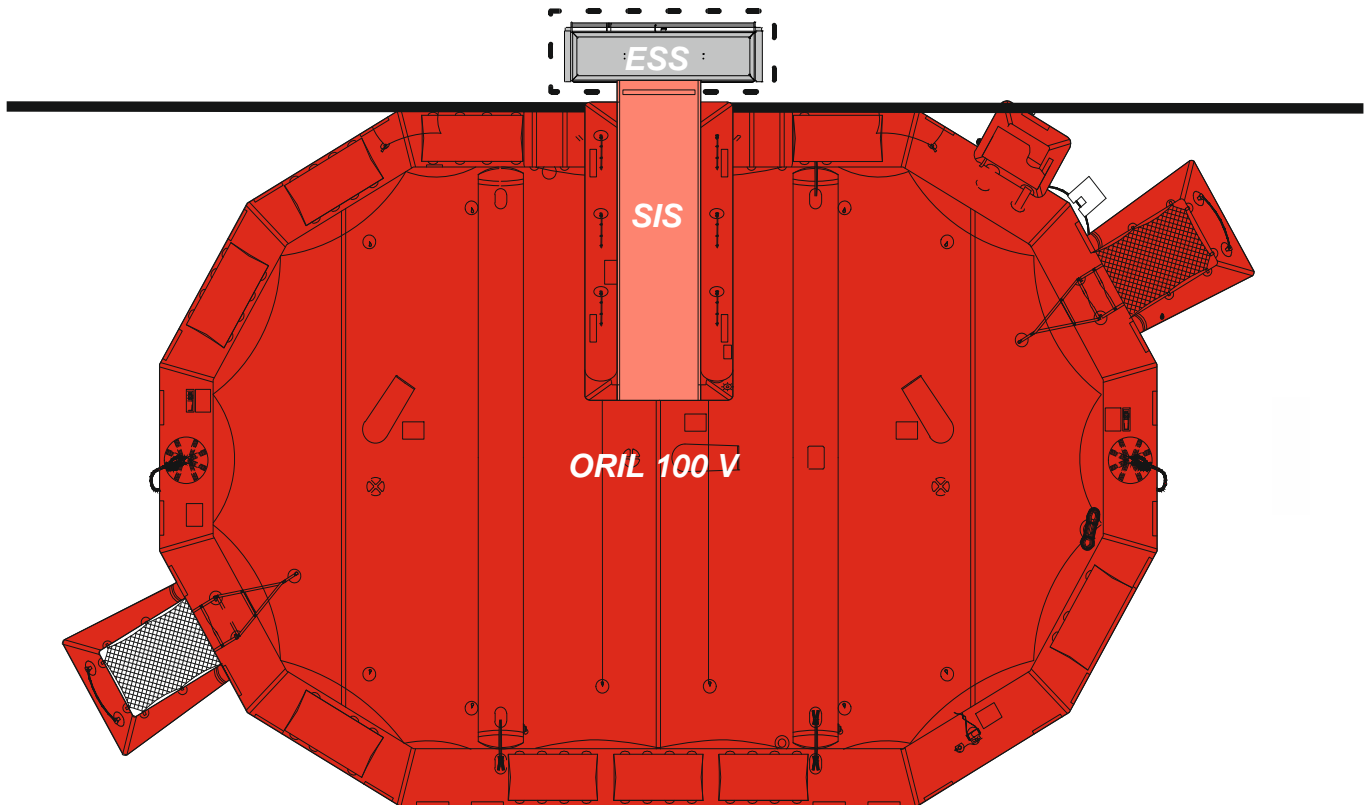

ESS box model « 850 »

Maximum height stowage	1,70 m		
ESS			
Complete System Dimensions	X: 1845mm	Y: 611mm	Z: 1420mm
	X: 6' 0,64"	Y: 2' 0,06"	Z: 4' 7,91"
System Net Weight	430 kg / 948 pounds		

Maximum height stowage	2,20 m		
ESS			
Complete System Dimensions	X: 1845mm	Y: 611mm	Z: 1420mm
	X: 6' 0,64"	Y: 2' 0,06"	Z: 4' 7,91"
System Net Weight	434 kg / 957 pounds		

Maximum height stowage	2,70 m		
ESS			
Complete System Dimensions	X: 1845mm	Y: 611mm	Z: 1420mm
	X: 6' 0,64"	Y: 2' 0,06"	Z: 4' 7,91"
System Net Weight	442 kg / 975 pounds		

Maximum height stowage	3,20 m		
ESS			
Complete System Dimensions	X: 1845mm	Y: 611mm	Z: 1420mm
	X: 6' 0,64"	Y: 2' 0,06"	Z: 4' 7,91"
System Net Weight	443,5 kg / 978 pounds		

Maximum height stowage	3,80 m		
ESS			
Complete System Dimensions	X: 1845mm	Y: 611mm	Z: 1420mm
	X: 6' 0,64"	Y: 2' 0,06"	Z: 4' 7,91"
System Net Weight	452 kg / 997 pounds		

Approvals:	EC
-------------------	-----------

ESS MES SIS CBL 100 V_boite 850_26072017 KLT	Issue: -	Date: 26/07/2017
--	----------	------------------

Dimensions and weight +/- 5%
 SURVITEC SAS reserves the right to change specification without notice.
 For installation, add minimum +10mm for clearance to dimensions of the container.