

MARINE EVACUATION SYSTEM (MES) 50 TO A Pack WITH CENTRAL BOWSING LINES ASSOCIATED WITH SMALL INFLATABLE SLIDE (SIS) & AUTOMATIC EVACUATION SLIDE SYSTEM (ESS)

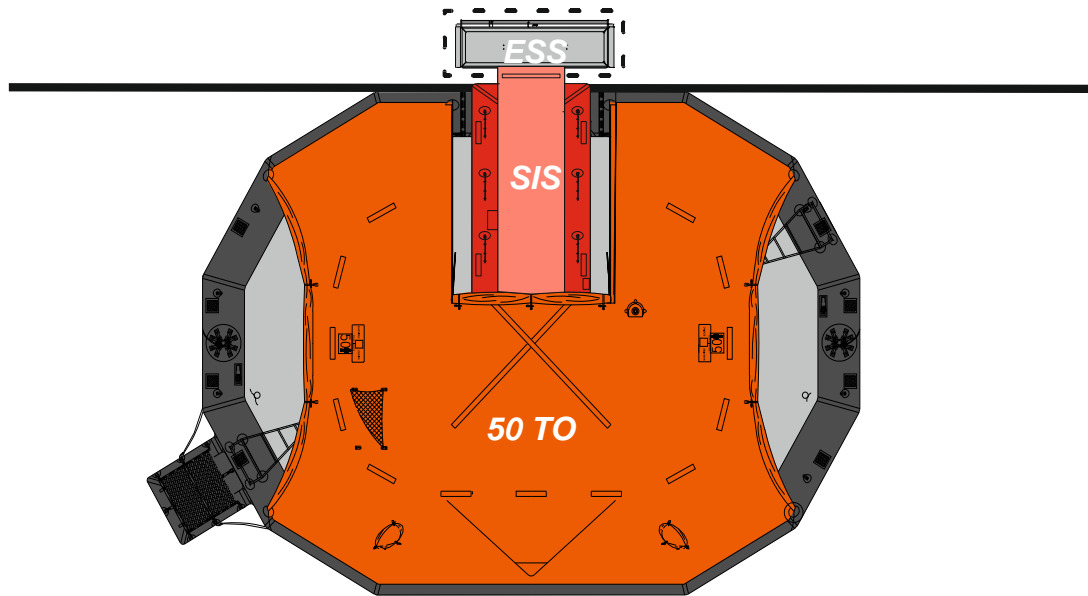

ESS 50 TO A Pack	ESS 1000		
Maximum height of stowage (SIS)	3,80m		
Complete System Dimensions	X: 2128mm	Y: 611mm	Z: 1645mm
	X: 6' 11,78"	Y: 2' 0,06"	Z: 5' 4,77"
System Net Weight	600 kg / 1323 pounds		

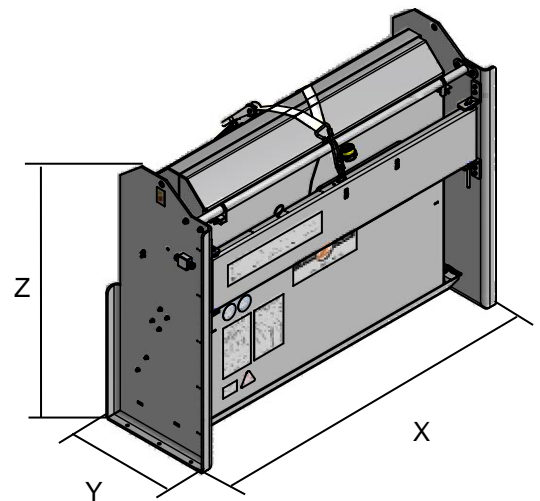

Approvals:	EC
-------------------	-----------

ESS MES SIS CBL 50 TO PA 22022017 KLT.doc	Issue: 1	Date: 22/02/2017
---	----------	------------------

Dimensions and weight +/- 5%
 SURVITEC SAS reserves the right to change specification without notice.
 For installation, add minimum +10mm for clearance to dimensions of the container.