

MARINE EVACUATION SYSTEM (MES) 50 MAN THROW OVER BOARD SELF RIGHTING LIFERAFT ASSOCIATED WITH SMALL INFLATABLE SLIDE (SIS)

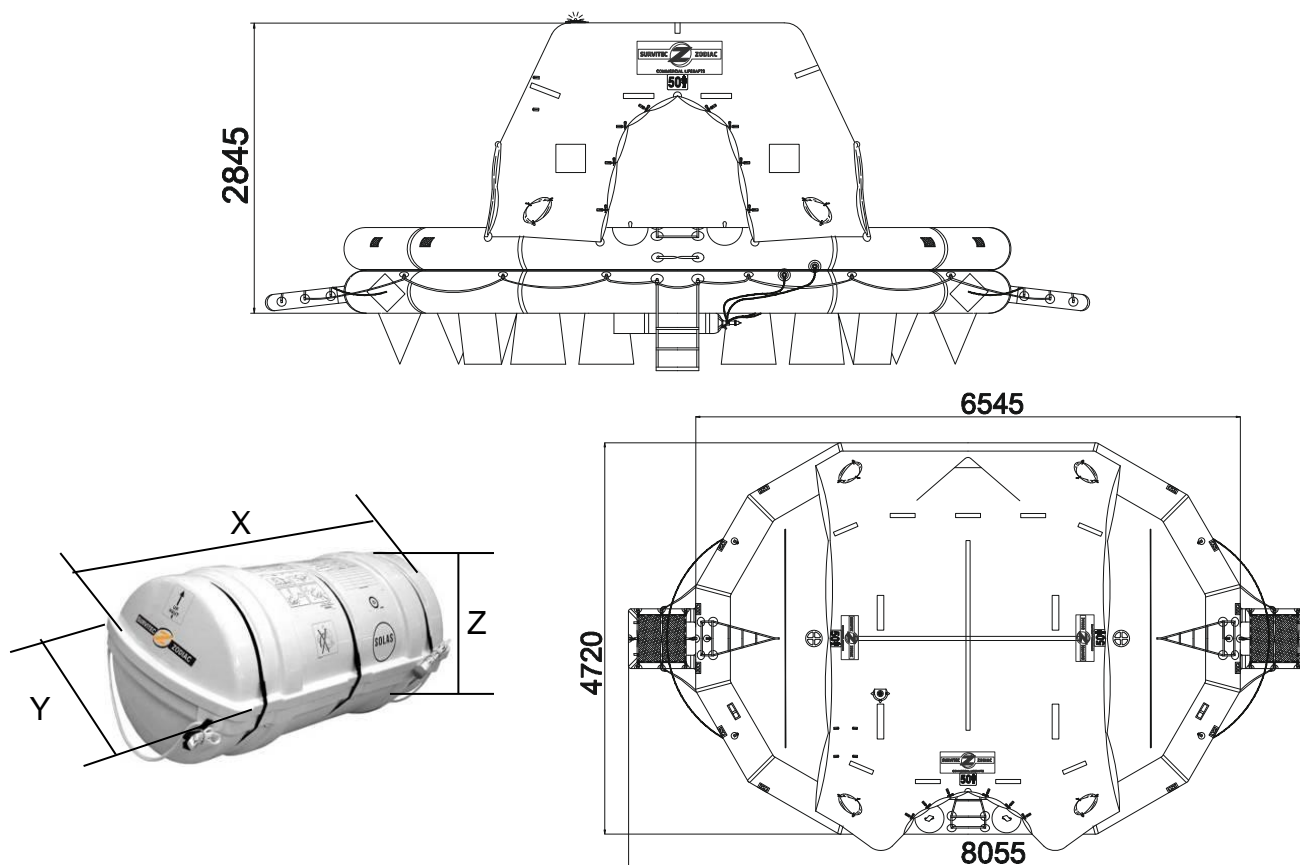
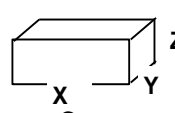

50 MAN MES SIS	A PACK			B PACK		
Container	N20			N18		
Dimensions	X: 1560 mm X: 5' 1,42"	Y: 952 mm Y: 3' 1,49"	Z: 960 mm Z: 3' 1,8"	X: 1560 mm X: 5' 1,42"	Y: 852 mm Y: 2' 9,55"	Z: 835 mm Z: 2' 8,88"
Liferaft Net Weight	360 kg / 794 pounds			236 kg / 521 pounds		
Max. height storage	25 m / 83'			27 m / 89'		
Painter line length	35 m / 115'					
Inflation Cylinder	2 x 27 liter					
 Crate	X: 1650 mm X: 5' 4,97"	Y: 1040 mm Y: 3' 4,95"	Z: 1160 mm Z: 3' 9,67"	X: 1645 mm X: 5' 4,77"	Y: 940 mm Y: 3' 1,01"	Z: 1050 mm Z: 3' 5,34"
	402 kg / 887 pounds			270 kg / 596 pounds		
	1,991 m3 / 70,29 cubic foot			1,624 m3 / 57,34 cubic foot		
Towing force	2 knots			3 knots		
Without sea anchor	160 daN			257 daN		
With sea anchor	193 daN			348 daN		

50 TO SR MES SIS 22022017 KLT.doc

Issue: 5

Date: 22/02/2017

Dimensions and weight +/- 5%
SURVITEC SAS reserves the right to change specification without notice.
For installation, add minimum +10mm for clearance to dimensions of the container.

SIS (SMALL INFLATABLE SLIDE)



Slide in valise

SIS	1,70 m			2,20 m		
Valise						
Dimensions	X:670mm	Y:300mm	Z:260mm	X:720mm	Y:425mm	Z:295mm
	X:2' 2,38"	Y:11,82"	Z:10,24"	X:2' 4,35"	Y:1' 4,74"	Z:11,62"
Slide net weight	15 kg / 34 pounds			19 kg / 42 pounds		
Max. evacuation height	1,70 m			2,20 m		
Firing line length	1,50 m			1,50 m		
Inflation cylinder	1 x 2,83 litres			1 x 4 litres		

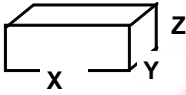
 Crate	X:830mm	Y:540mm	Z:330mm	X:830mm	Y:540mm	Z:330mm
	X:2' 8,68"	Y:1' 9,26"	Z:1' 1"	X:2' 8,68"	Y:1' 9,26"	Z:1' 1"
	17,6 kg / 39 pounds			21,6 kg / 48 pounds		
	0,148 m3 / 5,23 cubic foot			0,148 m3 / 5,23 cubic foot		

SIS	2,70 m			3,20 m		
Valise						
Dimensions	X:720mm	Y:450mm	Z:295mm	X:800mm	Y:450mm	Z:295mm
	X:2' 4,35"	Y:1' 5,72"	Z:11,62"	X:2' 7,5"	Y:1' 5,72"	Z:11,62"
Slide net weight	27 kg / 60 pounds			28,5 kg / 63 pounds		
Max. evacuation height	2,70 m			3,20 m		
Firing line length	1,50 m			1,50 m		
Inflation cylinder	1 x 6 litres			1 x 6,7 litres		

 Crate	X:830mm	Y:540mm	Z:330mm	X:830mm	Y:540mm	Z:330mm
	X:2' 8,68"	Y:1' 9,26"	Z:1' 1"	X:2' 8,68"	Y:1' 9,26"	Z:1' 1"
	29,6 kg / 66 pounds			31,1 kg / 69 pounds		
	0,148 m3 / 5,23 cubic foot			0,148 m3 / 5,23 cubic foot		

Approvals: **EC - TC**

50 TO SR MES SIS 22022017 KLT.doc Issue: 5 Date: 22/02/2017

Dimensions and weight +/- 5%
 SURVITEC SAS reserves the right to change specification without notice.
 For installation, add minimum +10mm for clearance to dimensions of the container.