

ORIL 50 WITH CENTRAL BOWSING LINES

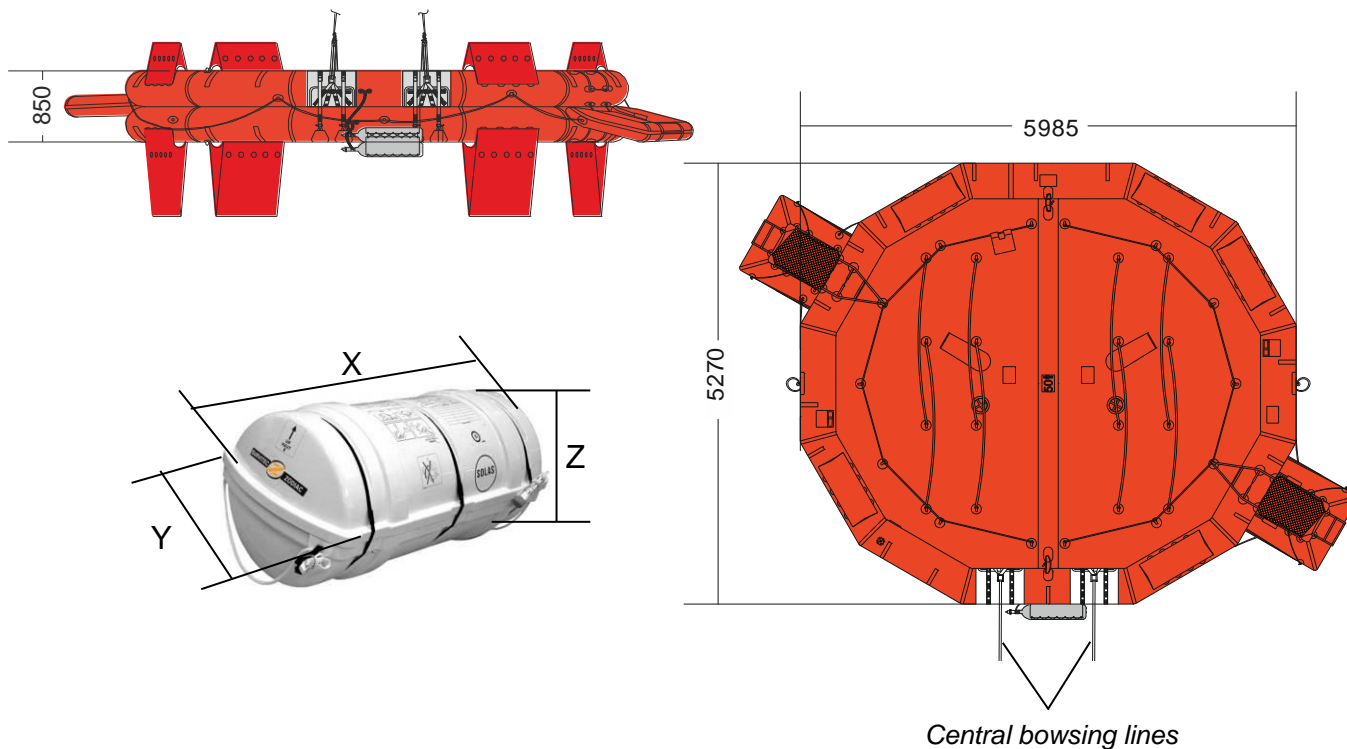
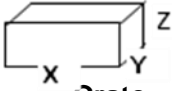

50 MAN CBL	HSC PACK		
Container	N15		
Dimensions	X: 1275 mm	Y: 800 mm	Z: 740 mm
	X: 4' 2,2"	Y: 2' 7,5"	Z: 2' 5,14"
Liferaft Net Weight	172 kg / 380 pounds		
Max. height stowage	18 m / 60'		
Painter line length	25 m / 83'		
Bowsing line length	17 m / 56'		
Inflation Cylinder	2 x 20 liter		
 Crate	X: 1350 mm	Y: 840 mm	Z: 900 mm
	X: 4' 5,15"	Y: 2' 9,08"	Z: 2' 11,44"
	195 kg / 430 pounds		
	1,021 m ³ / 36,04 cubic foot		
Towing force	2 knots	3 knots	
Without sea anchor	120 daN	195 daN	
With sea anchor	165 daN	270 daN	

Approvals:	EC
-------------------	-----------

ORIL 50 CBL 20022017 KLT.doc	Issue: 2	Date: 20/02/2017
------------------------------	----------	------------------

Dimensions and weight +/- 5%
 SURVITEC SAS reserves the right to change specification without notice.
 For installation, add minimum +10mm for clearance to dimensions of the container.